

C - profile

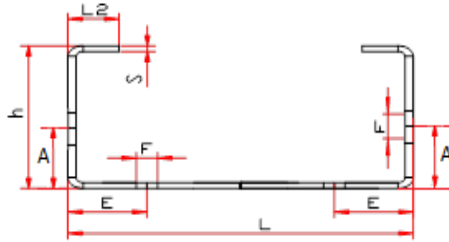

M 13, 16, 19, 25

Type	L, MM	h, MM	F, MM	A	E, MM	Thickness of metal S, MM					
						1,5	2	2,5	3	3,5	4
C150	150	50	14-16-18	1/2h	27	50	50	50			
	150	63	14-16-18	1/2h	27	63	63	63	63	63	
C180	180	50	14-16-18	1/2h	27	50	50	50	50		
	180	63	14-16-18	1/2h	27	63	63	63	63	63	
C200	200	50	14-16-18	1/2h	27	50	50	50	50		
	200	63	14-16-18	1/2h	27	63	63	63	63	63	63
	200	80	14-16-18	1/2h	27	80	80	80	80	80	80
C250	250	50	14-16-18	1/2h	27	50	50	50	50		
	250	63	14-16-18	1/2h	27	63	63	63	63	63	63
	250	80	14-16-18	1/2h	27	80	80	80	80	80	80
C300	300	50	14-16-18	1/2h	27	50	50	50	50		
	300	63	14-16-18	1/2h	27	63	63	63	63	63	63
	300	80	14-16-18	1/2h	27	80	80	80	80	80	80
C350	350	50	14-16-18	1/2h	27	50	50	50	50		
	350	63	14-16-18	1/2h	27	63	63	63	63	63	63
	350	80	14-16-18	1/2h	27	80	80	80	80	80	80
	350	100	14-16-18	1/2h	27	100	100	100	100	100	100
	350	110	14-16-18	1/2h	27		110	110	110	110	110
	350	120	14-16-18	1/2h	27		120	120	120	120	120
C400	400	63	14-16-18	1/2h	27	63	63	63	63	63	63
	400	80	14-16-18	1/2h	27	80	80	80	80	80	80
	400	100	14-16-18	1/2h	27	100	100	100	100	100	100
	400	110	14-16-18	1/2h	27		110	110	110	110	110
	400	120	14-16-18	1/2h	27		120	120	120	120	120

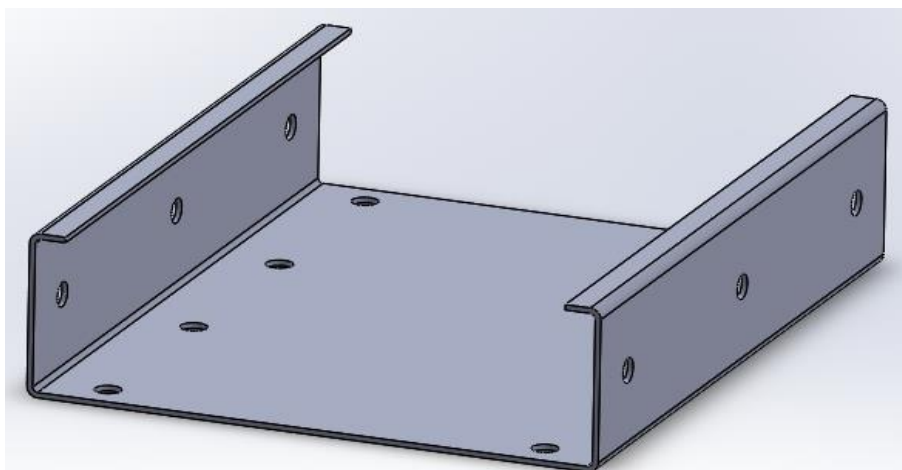

Z - profile

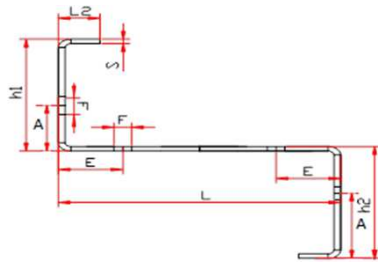

L2, № 13, 16, 19, 25

Type	L,MM	h1, MM	h2, MM	F,MM	A	E, MM	Thickness of metal S, MM						
							1,5	2	2,5	3	3,5	4	
Z150	150	50	50	14-16-18	1/2h1-h2	27	50	50	50				
	150	63	63	14-16-18	1/2h1-h2	27	63	63	63	63	63		
Z180	180	50	50	14-16-18	1/2h1-h2	27	50	50	50				
	180	63	63	14-16-18	1/2h1-h2	27	63	63	63	63	63		
Z200	200	50	50	14-16-18	1/2h1-h2	27	50	50	50	50			
	200	63	63	14-16-18	1/2h1-h2	27	63	63	63	63	63	63	63
Z250	200	80	80	14-16-18	1/2h1-h2	27	80	80	80	80	80	80	80
	250	50	50	14-16-18	1/2h1-h2	27	50	50	50	50			
	250	63	63	14-16-18	1/2h1-h2	27	63	63	63	63	63	63	63
	250	80	80	14-16-18	1/2h1-h2	27	80	80	80	80	80	80	80
Z300	250	100	100	14-16-18	1/2h1-h2	27	100	100	100	100	100	100	100
	300	50	50	14-16-18	1/2h1-h2	27	50	50	50	50	50		
	300	63	63	14-16-18	1/2h1-h2	27	63	63	63	63	63	63	63
	300	80	80	14-16-18	1/2h1-h2	27	80	80	80	80	80	80	80
	300	100	100	14-16-18	1/2h1-h2	27	100	100	100	100	100	100	100
	300	110	100	14-16-18	1/2h1-h2	27		110	110	110	110	110	110
	300	120	100	14-16-18	1/2h1-h2	27		120	120	120	120	120	120
	350	50	50	14-16-18	1/2h1-h2	27	50	50	50	50			
Z350	350	63	63	14-16-18	1/2h1-h2	27	63	63	63	63	63	63	63
	350	80	80	14-16-18	1/2h1-h2	27	80	80	80	80	80	80	80
	350	100	100	14-16-18	1/2h1-h2	27	100	100	100	100	100	100	100
	350	110	100	14-16-18	1/2h1-h2	27		110	110	110	110	110	110
	350	120	100	14-16-18	1/2h1-h2	27		120	120	120	120	120	120
	375	63	63	14-16-18	1/2h1-h2	27	63	63	63	63	63	63	63
Z375	375	80	80	14-16-18	1/2h1-h2	27	80	80	80	80	80	80	80
	375	100	100	14-16-18	1/2h1-h2	27	100	100	100	100	100	100	100
	375	110	100	14-16-18	1/2h1-h2	27		110	110	110	110	110	110
	375	120	100	14-16-18	1/2h1-h2	27		120	120	120	120	120	120
Z400	400	63	63	14-16-18	1/2h1-h2	27	63	63	63	63	63	63	63
	400	80	80	14-16-18	1/2h1-h2	27	80	80	80	80	80	80	80
	400	100	100	14-16-18	1/2h1-h2	27	100	100	100	100	100	100	100
	400	110	100	14-16-18	1/2h1-h2	27		110	110	110	110	110	110
	400	120	100	14-16-18	1/2h1-h2	27		120	120	120	120	120	120

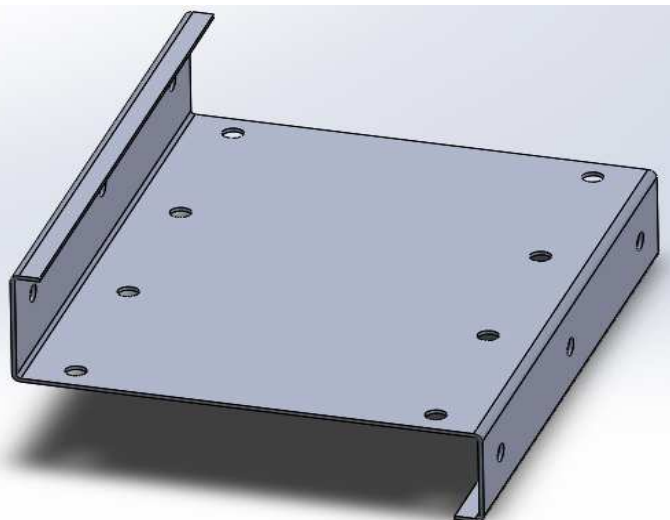

Sigma - profile

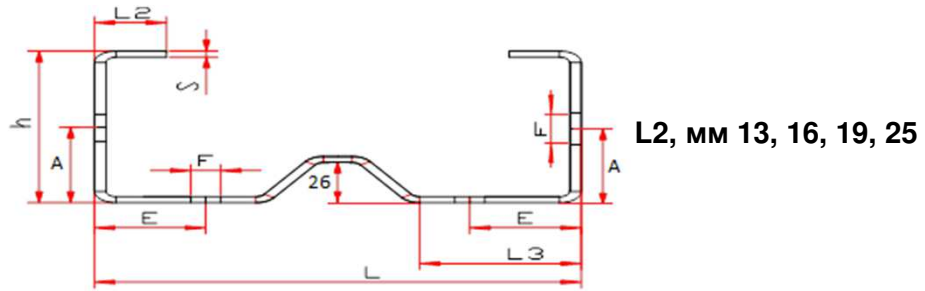

Type	L, MM	h, MM	L3, MM	F,MM	A	E,MM	Thickness of metal S, MM					
							1,5	2	2,5	3	3,5	4
180	180	50	50	14-16-18	1/2h	27	50	50	50	50		
	180	63	50	14-16-18	1/2h	27	63	63	63	63	63	
200	200	50	50	14-16-18	1/2h	27	50	50	50	50		
	200	63	50	14-16-18	1/2h	27	63	63	63	63	63	63
	200	80	50	14-16-18	1/2h	27	80	80	80	80	80	80
250	250	50	50	14-16-18	1/2h	27	50	50	50	50		
	250	63	50	14-16-18	1/2h	27	63	63	63	63	63	63
	250	80	50	14-16-18	1/2h	27	80	80	80	80	80	80
300	300	50	50	14-16-18	1/2h	27	50	50	50	50		
	300	63	50	14-16-18	1/2h	27	63	63	63	63	63	63
	300	80	50	14-16-18	1/2h	27	80	80	80	80	80	80
	300	100	50	14-16-18	1/2h	27	100	100	100	100	100	100
350	350	50	50	14-16-18	1/2h	27	50	50	50	50		
	350	63	50	14-16-18	1/2h	27	63	63	63	63	63	63
	350	80	50	14-16-18	1/2h	27	80	80	80	80	80	80
	350	100	50	14-16-18	1/2h	27	100	100	100	100	100	100
	350	110	50	14-16-18	1/2h	27		110	110	110	110	110
400	400	50	50	14-16-18	1/2h	27	50	50	50	50		
	400	63	50	14-16-18	1/2h	27	63	63	63	63		
	400	80	50	14-16-18	1/2h	27	80	80	80	80	80	80
	400	100	50	14-16-18	1/2h	27	100	100	100	100	100	100
	400	110	50	14-16-18	1/2h	27		110	110	110	110	110
	400	120	50	14-16-18	1/2h	27		120	120	120	120	120

